

AM WP 1000®
Micro Rib Flat Panel

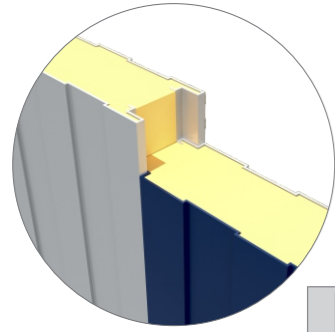

Design Information

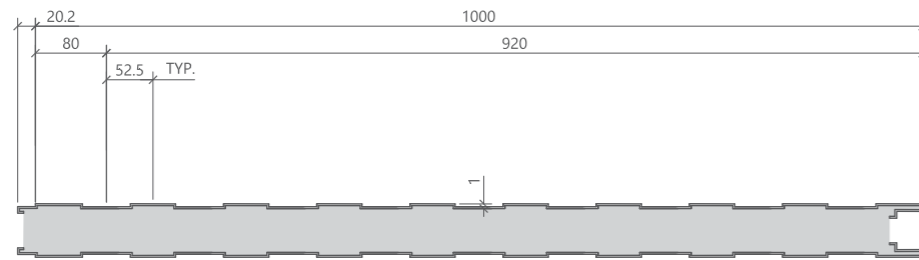

AM CP 1000®
Cold Room Panel

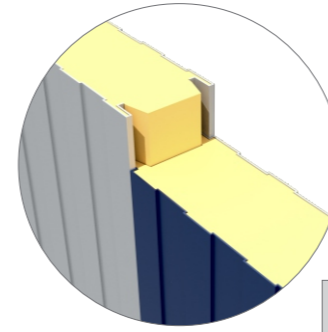

Design Information

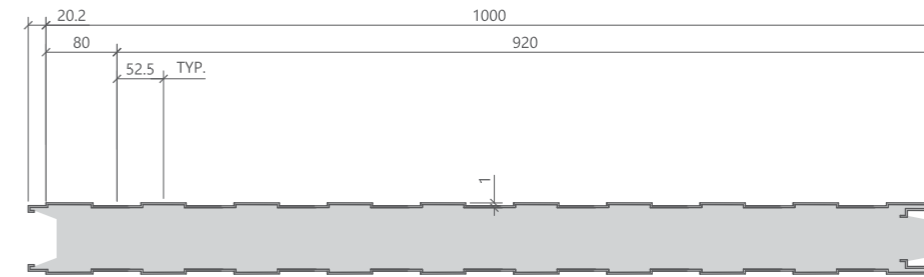

Specification for Insulation - Wall Panels

POLYISOCYANURATE PROPERTIES Polyisocyanurate Panel U Value Chart					
Core Thickness in mm		50	75	100	
Overall Heat Transfer Coefficient # U # Value					
Wm ² K or Wm ² C		0.42	0.24	0.23	
Mechanical Characteristic of Polyurethane Insulation					
Density	Tensile Stress	Compression Resistance	Shear Resistance	Fire Property	Closed Cell content
35-40Kg/m3 (as per BSEN 1602: 1997)	150 kpa (as per BSEN 1608: 1997)	100 kpa (as per ASTM C165 : 2000)	150 kpa (as per ASTM 271/ 271M)	B2/ B3 as per DIN 4102-1	> 94%
POLYURETHANE PROPERTIES Polyurethane Panel U Value Chart					
Core Thickness in mm		50	75	100	
Overall Heat Transfer Coefficient # U # Value					
Wm ² K or Wm ² C		0.38	0.26	0.21	
Mechanical Characteristic of Polyisocyanurate Insulation					
Density	Tensile Stress	Compression Resistance	Shear Resistance	Fire Property	Closed Cell content
40-45 Kg/m3 (as per BSEN 1602: 1997)	Greater than 100 kpa (as per BSEN 1608: 1997)	Greater than 120 kpa (as per ASTM C165 : 2000)	>100 kpa (as per ASTM 271/ 271M)	B2/ B1 as per DIN 4102 - 1	> 94%

Cold Room Panel Properties

Nominal Panel Thickness (mm)	U-Value - PU (W/m ² °C)	U-Value - PIR (W/m ² °C)	Panel Weight (kg/m ²)	Maximum Wall Height (m)	Maximum Ceiling Span (m)
100	0.230	0.210	12.5	8.0	5.0
150	0.153	0.140	14.6	12.0	7.0
200	0.115	0.105	16.7	15.0	8.5

